

## CANON INCREASES EFFICIENCY BY CONSOLIDATION

**“We have more than recovered our investments in data conversion and interfaces.”**

Bert Ramkisoen-Panday, senior project manager European IT Competence Center, Canon Europe

It is Scamander Solutions' mission to give people and organizations freedom of choice and action, by liberating their business data. Sailing is a symbol of this freedom.

### CANON; LEADING INNOVATOR

Canon Europe is a subsidiary company of the global giant Canon Inc. in Japan, with a turnover of 21,870 million euro. Canon Inc. (NYSE: CAJ) and the Canon Group develop, produce and market a wide range of products used in the home, offices and industry, including business machines, conventional and digital cameras, lenses, digital video camcorders, semiconductor production equipment, television broadcasting lenses and medical equipment.

### CANON OPTED FOR SMARTDB

SmartDB consists of a series of intelligent adapters which enable data to be exchanged between systems (applications, databases, etc.). One of the European distributors of the SmartDB product line of intelligent adapters is Scamander Solutions. Adapters are available for the best-known enterprise applications, such as the Oracle E-Business Suite, which is used by Canon. It is also possible to develop one's own adapters, or to have them developed. Further information is available at: [www.scamander.com](http://www.scamander.com).

### RESULTS ACHIEVED WITH CANON

- Considerable savings on costs
- More efficient and uniform operating processes
- Central recording of data
- Up-to-date information for staff all over Europe

### FROM LOCAL TO CENTRAL

Canon Europe has its headquarters in Amstelveen (the Netherlands) and sales offices in 12 European countries. The organization is in the process of moving from local to central IT facilities. A few years ago, Canon decided to enter into a full-scale consolidation, in which the IT support, with the exception of office computerization, would be provided centrally from the European head office in the Netherlands. Part of this extensive operation was the consolidation of all the company data in a single central Oracle database. The data comes from internal applications, such as HRM systems and ERP systems, as well as from external applications, including those for banking and warehousing.



Canon Europe's offices in Amstelveen, The Netherlands.

### GOAL: OPTIMAL EFFICIENCY

Storing the company data centrally should make it possible for Canon to support the operational processes of all the European sales offices from Amstelveen. All the staff will thus have access to the same data, which are always up-to-date and in the correct format. Canon sees this as a big step towards optimal efficiency and even better operating results.

### DATA FLOW?

First of all, Canon consolidated the computerization of the activities of Canon Consumer Imaging, which is concerned with selling digital cameras and desktop printers to retailers. Bert Ramkisoen-Panday, senior project manager of Canon's European IT Competence Center, said "We started this in 2001. We opted for a phased rollout, per country. The size of this project, and the large-scale approach to it, was unprecedented for Canon, and the first steps were taken with this CCI project."

Company data had to be converted and stored in the central database. Canon looked for a tool which could handle this conversion and which could also provide access to the stored data for the many applications used by Canon, including CRM and EIS (Executive Information Systems). Bert Ramkisoen-Panday added: "We had also decided to optimize our supply chain. This meant that we had to develop interfaces with our regional warehouses, so that our colleagues throughout Europe had direct insight into the state of product supplies and orders."

Scamander Solutions already had a strong partnership with Canon Europe and advised using SmartDB for this. Following a selection process, Canon did indeed choose SmartDB, which seemed capable of dealing with the data flow to and from the central database. Canon took just 15 months to finalize this first big round of consolidation in 12 countries. Scamander's support in this went much further than merely implementing SmartDB, and their expertise in the field of data migration and integration proved its worth.

Richard Slingerland (l.) of Scamander Solutions and Bert Ramkisoen-Panday, senior project manager of Canon's European IT Competence Center.



**PHASE 2: TRI.CAN**

Then followed an even larger project, namely the consolidation at Canon Business Solutions. The main activity here is the rental and leasing of Canon Copiers to businesses and organizations, either with or without a service contract. This operation is also taking place in 12 European countries, but is even more radical, as the ICT facilities are being completely replaced. Bert Ramkisoen-Panday: "We are migrating all the data from the legacy systems to a second central Oracle database. This project is more extensive than the CCI project, but it is clear to us that we have gained a lot of experience with the material through the CCI project." Here, too, Canon is using SmartDB, for the conversion of data and interfacing between ICT systems.

**DATA LIBERATION PROVES ITS WORTH**

Bert Ramkisoen-Panday tells how Scamander Solutions became involved in these two consolidation projects: "Our technical teams needed a solid middleware tool. We drew up a shortlist, which included SmartDB. Scamander gave a proof-of-concept, which showed that the claims about functionality were correct and also that the technical realization was easy to implement."

Scamander provided the installation of SmartDB and the training of managers and developers. Scamander's specific knowledge of data liberation also enabled them to give Canon good advice on data consolidation and to assist in its implementation.

"A large part of our success was due to Scamander's expertise and their customer-friendly approach", said Bert Ramkisoen-Panday frankly. "The people at Scamander each have their own personality and expertise but, as a customer, you receive exactly the person you need for the project. With Scamander, we have more than recovered our investments in data conversion and interfaces."

**INNOVATION AND GROWTH**

Bert Ramkisoen-Panday thinks that SmartDB is an excellent product for use over a longer period: "We shall be using it for many of our future projects. Canon is always concerned with innovation and we believe that Scamander and SmartDB will definitely continue to make a positive contribution to this."

**SCAMANDER SOLUTIONS:**  
The Data Liberation Company

The simplicity with which data is entered into your application system stands in stark contrast to the time and trouble that is necessary for releasing it again. Result: you do not get the required information in time. Scamander Solutions can provide the expertise and tools to give you fast, simple and secure insight into your company data. Experience the smooth running of your operational processes again!

**OUR ADDRESS**

Scamander Solutions BV  
Weverstede 5  
3431 JS Nieuwegein The Netherlands  
Tel.: +31-(0)30-6029000  
Fax: +31-(0)30-6029010  
E-mail: info@scamander.com  
www.scamander.com

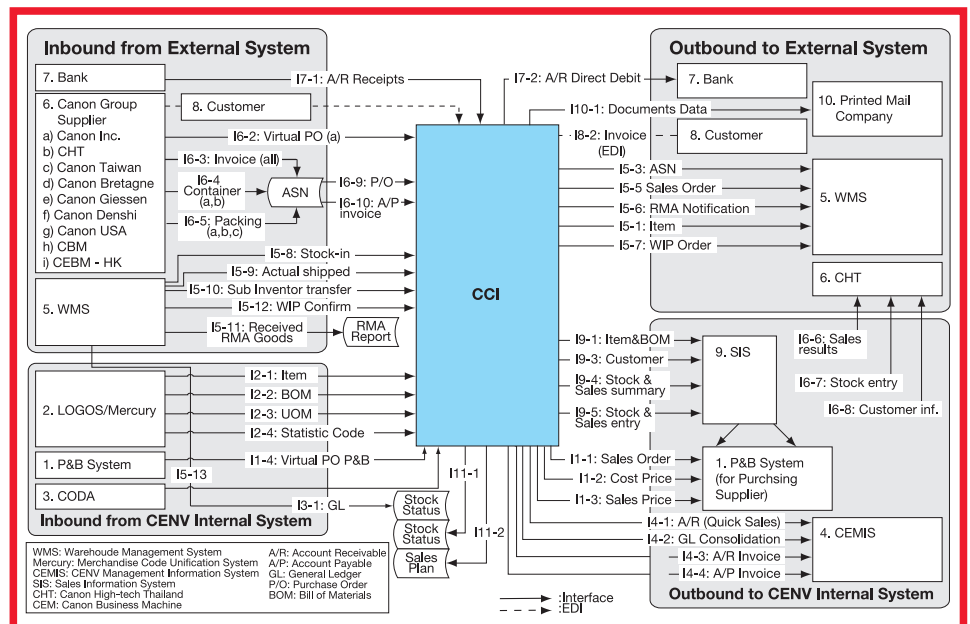

Centralized data storage at Canon Consumer Imaging. Left; the external applications, right; the internal applications.